

RETAILER INSTALLATION INSTRUCTIONS

DWG # 2003-R4 | DRAWN BY: MLW | REV DATE: 12-19-2007

OPENING PREPARATION

MEASURE WIDTH AND HEIGHT OF FRAMED OPENING AND COMPARE WITH OTHER DIMENSIONS.

FRAMED OPENING DIMENSIONS MUST MEET ORDER DIMENSIONS WITHIN THE FOLLOWING TOLERANCES:

SINGLE DOORS: HEIGHT: ±1/4"
 WIDTH: ±1/4"

DOUBLE DOORS: HEIGHT: ±1/4"
 WIDTH: ±1/4"

IF THE FRAMED OPENING DOES NOT MEET THE ORDER DIMENSIONS WITHIN THESE TOLERANCES CALL THE FACTORY AT 1-800-547-6856

FOR PROPER INSTALLATION

FRAMED OPENINGS MUST BE SQUARE AND PLUMB. MAKE ANY NECESSARY ADJUSTMENTS TO SQUARE AND PLUMB OPENING. DURULITE DOORS MUST BE INSTALLED PLUMB.

DRILL BIT SIZES

FOR: (1) (2)

FOR STEEL JAMBS

USE: 1/8" DRILL BIT FOR JAMBS UP TO 3/8" THICK.
 USE 3/16" BIT FOR JAMBS IN EXCESS OF 3/8" THICK.

FOR WOOD JAMBS

USE: 3/16" DRILL BIT.

FASTENERS

FOR: (1) (2)

FOR STEEL JAMB

USE: (2) 1/4-20 X 1-3/4" TEK SCREWS ON BASE OF V-CAM

(1) 1/4-20 X 1-3/4" TEK SCREW ON TOP OF V-CAM [(2) FOR OLD STYLE]

(4) 1/4-20 X 1-3/4" TEK SCREW ON JAMB SIDE OF LOWER HINGE GUARD

FOR WOOD JAMB

USE: 1/4" X 3" WOOD SCREWS

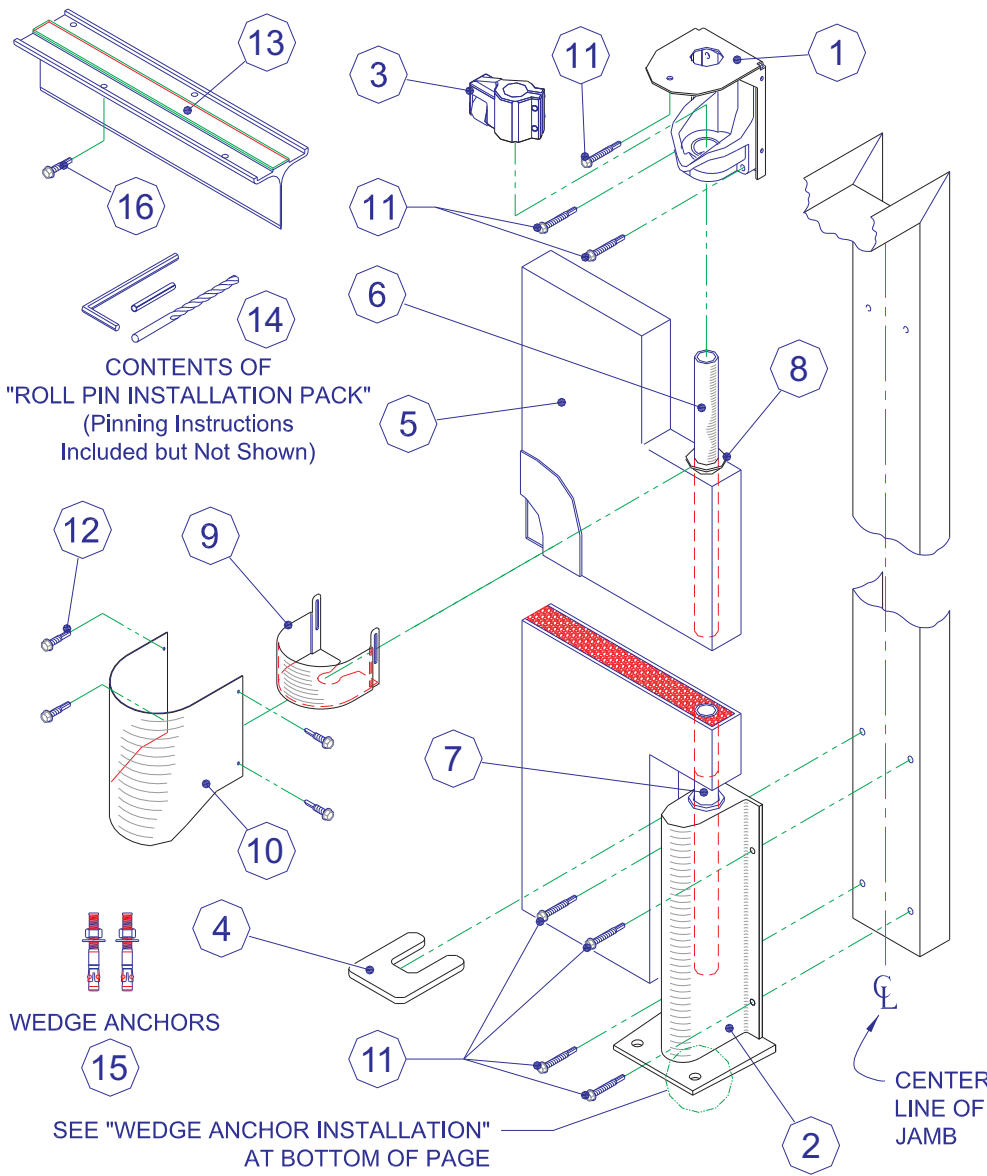

Figure 1

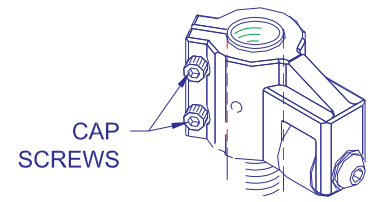

Figure 6

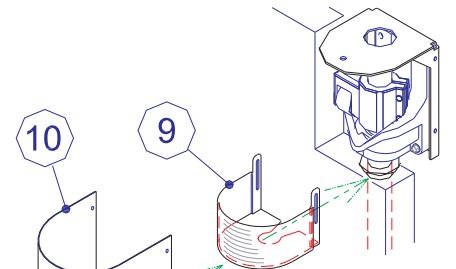

Figure 7-A

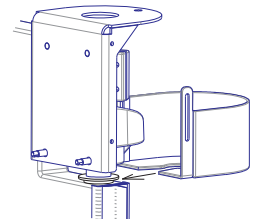

Figure 7-B

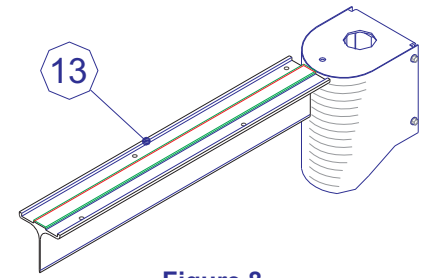

Figure 8

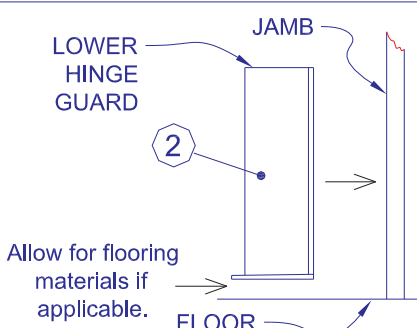

Figure 2

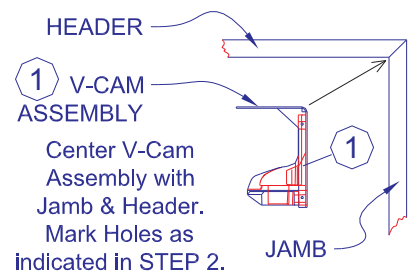

Figure 3

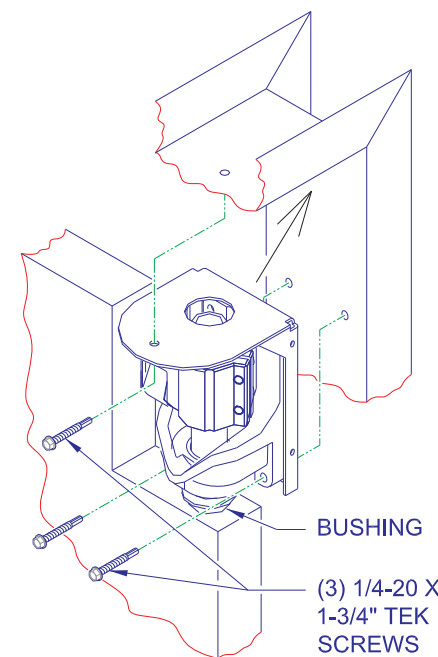

Figure 4

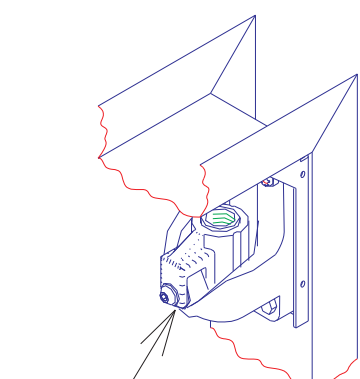

Figure 5

STEP 1. MARKING & DRILLING PILOT HOLES

IMPORTANT NOTE: If a flooring material is to be added at a later time it will be necessary to adjust the height of the door accordingly. The entire lower hinge assembly must be raised the thickness of the flooring material to be applied. It is recommend that you use a temporary shim, or spacer, under the base of the lower hinge guard while installing the door.

Place the Lower Hinge Guard (2) into the lower corner of Jamb/Floor, see Figure 2. Center the Lower Hinge Guard with the Jamb as shown in Figure 1, and mark holes on Jamb with pencil or center punch. Place the V-Cam Assembly (1) in the upper corner of Jamb/Header as shown in Figure 3. Center the V-Cam Assembly with the Jamb/Header and mark holes with pencil or center punch. Drill the marked holes on Jamb and Header with appropriate size drill bit, see "Drill Bit Sizes" at left.

STEP 2. UPPER HINGE ASSEMBLY

Remove the Roller Assembly (3) from the Upper Hinge Post (6), **DO NOT REMOVE THE BUSHING (8)**. Place the V-Cam Assembly (1) over the Upper Hinge Post (6). Slide the Roller Assembly (3) onto the Upper Hinge Post (6) above the inside flat of the V-Cam oriented with the bearing wheel facing down (see Figures 1 & 4). **NOTE: Do Not Tighten Cap Screws on the Roller Assembly at This Time.**

STEP 3. MOUNTING DOOR IN OPENING

Lift the door panel up and slide the Lower Hinge Post (7) into the top hole of the Lower Hinge Guard (2), see Figure 1. Place the completed door assembly into the jamb and line up with the pilot holes drilled in Step 3. It may be necessary to slide the V-Cam and Roller Assemblies down on the hinge post to fit the entire panel assembly into the jamb. Once inside the jamb you can lift the V-Cam and Roller Assemblies to the upper corner as indicated by the Arrow in Figures 3 & 4. Insert the two lower 1 3/4" Tek Screws (11) into the lower portion of the V-Cam Assembly (1) and tighten securely. Insert four 1 3/4" Tek Screws (11) into the Lower Hinge Guard (2) mounting holes and tighten securely. Insert a 1 3/4" Tek Screw (11) into the top hole of the V-Cam Assembly (1) at the header and tighten securely.

STEP 4. SETTING DOOR SWING

Lift the door panel and place the Door Adjusting Shim (4) between the Lower Hinge Guard (2) and the lower hinge cutout on the door panel, see Figure 1. **IMPORTANT: Do Not Allow Door Adjuster Shim To Rest On The Bushing!** Set the Roller Bearing to the Lowest point on the V-Cam (closed position), see Figure 5. Line up the centerline of the panel (5) with the centerline of the header and tighten the TOP Cap Screw on the Roller Assembly (3) securely, see Figure 6. Lift door high enough to gain access to the Lower Cap Screw on the Roller Assembly (3), see Figure 6. Tighten the Lower Cap Screw securely.

Open the door completely and let it go, allowing the door to rest in the center of the opening. If the Door is resting in the center of the opening and is completely closed, then you may proceed with the Pinning of the Roller Assembly. See "Roll Pin Installation Pack" (14).

WARNING: FAILURE TO COMPLETE THE INSTALLATION OF THE ROLL PIN AS DIRECTED IN THE INSTRUCTIONS INCLUDED IN THE "ROLL PIN INSTALLATION PACK" WILL VOID THE WARRANTY ON YOUR DURULITE RETAILER DOOR!

STEP 5. HINGE SEAL INSTALLATION

Make Absolutely Sure that the Snap Bushing (8) is pressed all the way down to the bottom of the Upper Hinge Shaft (6) with the **Flanged Side UP**, see Figure 7-B. Grasp the Hinge Seal Riser (4) firmly in your hand with the opening away from you and toward the Upper Hinge Shaft (6), as shown in Figure 7 A & B, and Press the Hinge Seal Riser onto the Snap Bushing directly below the Flange.

IMPORTANT NOTE: The Hinge Seal Riser (4) should rotate freely around the Snap Bushing and Upper Hinge Shaft. If the Hinge Seal Riser does not rotate freely it may be necessary to remove the Hinge Seal Riser and scrape the inside edges of the center hole.

Locate the Hinge Seal Wrap (10). Hold the Hinge Seal Wrap (10) with the straight edge toward the header as shown in Figures 1 & 7-A. Place one side of the Hinge Seal Wrap at the back edge of the V-Cam Assembly (1) and line up the mounting holes in the Hinge Seal Wrap with the two mounting holes on the back of the V-Cam Assembly. Insert two of the #10 x 1/2" TEK Screws (12) through the holes in the Hinge Seal Wrap and into the V-Cam Assembly. **DO NOT COMPLETELY TIGHTEN THE SCREWS AT THIS TIME!**

Slide the free end of the Hinge Seal Wrap through the opening between the V-Cam Assembly and the Door Panel. Line up the mounting holes and insert two #10 x 1/2" TEK Screws (12). The #10 x 1/2" TEK Screws must sit inside of the two slots on the sides of the Hinge Seal Riser (4). **Make any necessary adjustments to ensure that the Hinge Seal Riser moves up and down freely without binding.** Hold the top of the Hinge Seal Wrap so it comes in contact with the header and tighten the #10 x 1/2" TEK Screws securely. **DO NOT OVER TIGHTEN THESE SCREWS OR YOU WILL DAMAGE THE HINGE SEAL WRAP!**

STEP 6. TOP SEAL INSTALLATION

The Top Seal (13) is cut to length at the Factory (Some Trimming May Still Be Required). Remove the Paper from the Double Faced Tape on the back side of the Top Seal. Place the Top Seal in the center of the header with the Taped Side Up, See Figure 8. Top Seal must fit between the Hinge Seals on Double Doors and between the Hinge Seal and opposite Jamb on Single Doors. Once the Top Seal is placed in the desired position, insert the 24 x 1 1/4" TEK Screws (16) and tighten securely. You may wish to drill pilot holes, use top seal as a template.

Using a 3/8" diameter carbide tip bit, drill a hole into the floor material to a minimum depth of 2-1/2" deep, see Figure 9-A. Use High Pressure Air to clear the hole of debris. Assemble the nut and washer so that the top of the nut is flush with the top of the anchor, see Figure 9-B.

Drive the anchor into the hole until the nut and washer are flush with the base plate, see Figure 9-B.

WEDGE ANCHOR INSTALLATION

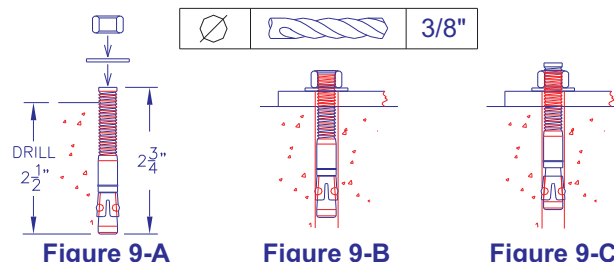

Figure 9-A

Figure 9-B

Figure 9-C

A Torque Wrench is recommended for optimum performance (refer to chart below).

Tighten the nut to between 2 & 5 turns past hand tight, see Figure 9-C.

ANKR-TITE
(Torque Setting ONLY)

Size	Torque
Ø 3/8"	20 - 25 ft. lbs.

OPENING HEIGHT	ACTUAL DOOR HEIGHT	DIM "A"
78"	75"	72.5"
80"	77"	74.5"
84"	81"	78.5"
90"	87"	84.5"
94"	91"	88.5"
96"	93"	90.5"
108"	105"	102.5"

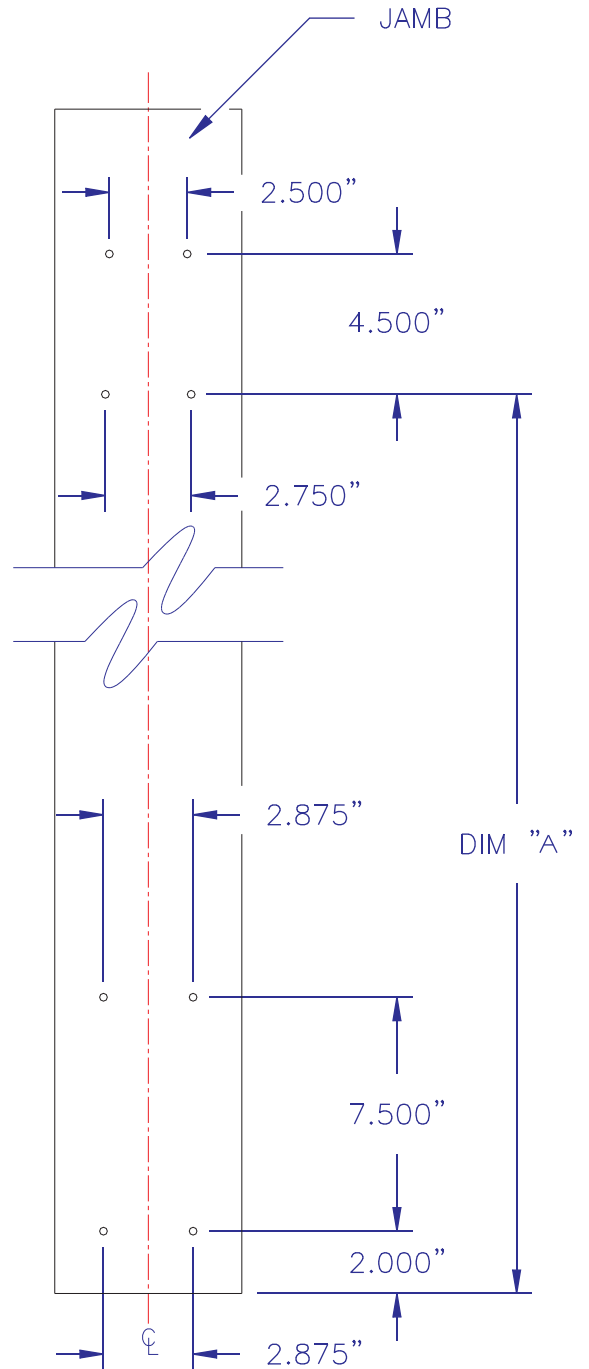

RETAILER (New V-Cam)



Chase Doors

World's Leading Manufacturer Of Traffic Doors

Cincinnati Ohio, and Redmond Oregon

Phone Toll Free: 1-800-543-4455 • www.chasedoors.com

Title: RETAILER HARDWARE LOCATIONS

Drawn By: MLW

DWG Name: RET_HW_NewHoles.dwg

Scale: N.T.S.

Sheet Size: A

Sheet 1 of 1

Date: 11-10-06