

# R-PLUS

COLD STORAGE DOORS

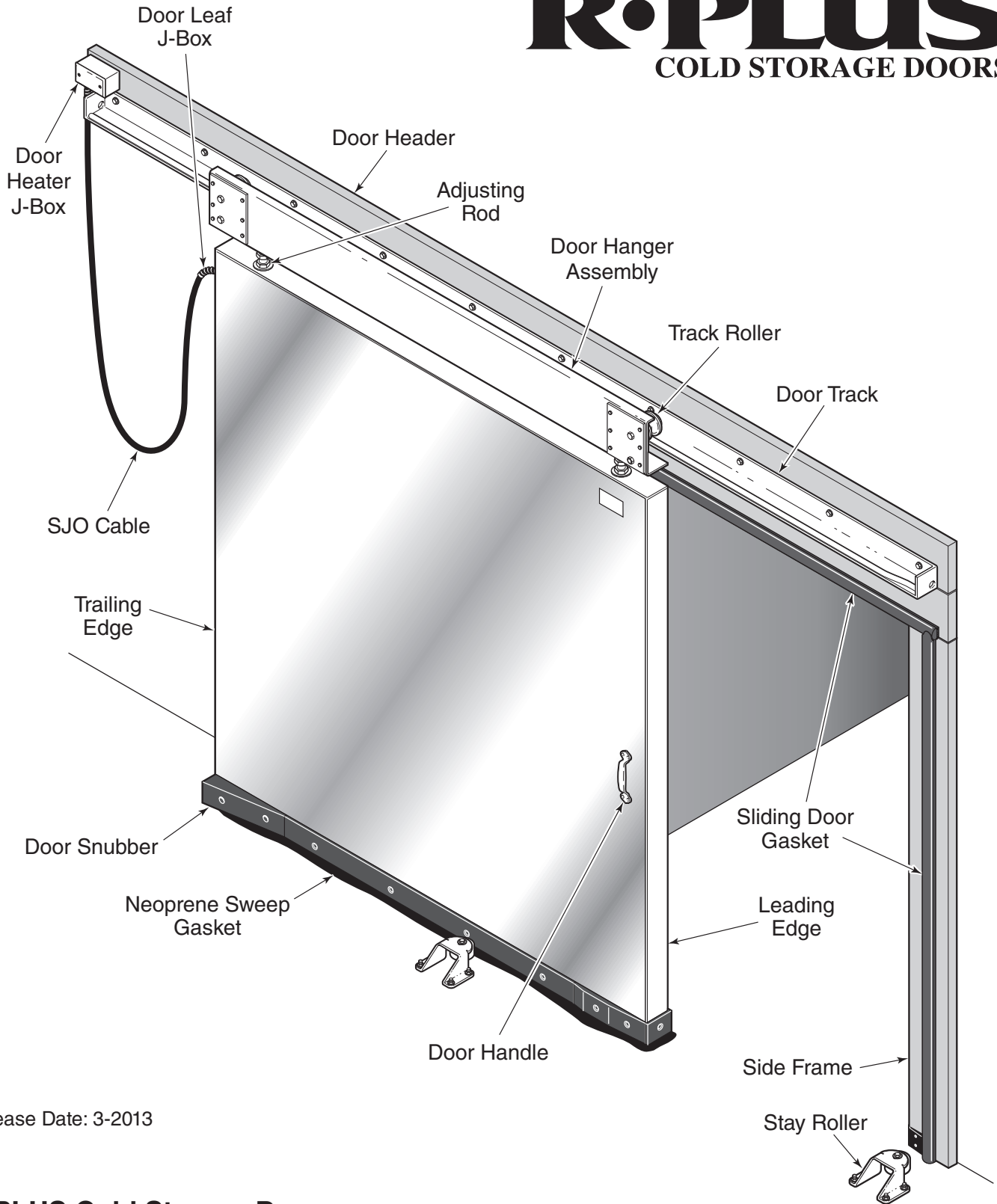

Release Date: 3-2013

## R-PLUS Cold Storage Doors

2271 NE 194th • Portland, Oregon 97230

Toll Free (877) 320-3599 • Fax (503) 665-2929 • [www.RPlusDoors.com](http://www.RPlusDoors.com)

**Table of Contents**

	Page
Warnings and Cautions .....	3
Attaching Door Frames to Wall .....	4
Joining Door Sections with Cam Locks .....	5
Assemble and Install Door and Door Hanger .....	6
Adjusting the Door Height .....	6
Stay Roller Installation .....	7
Door Gasket Adjustment .....	8
Heat Cable Wiring .....	9
Door SJO Cable(s)	
Periodic Maintenance .....	10

**IMPORTANT**

1. **Read all instructions!**
2. Please *review all* illustrations and drawings *before installing* the door.
3. Inspect and report any damage and/or missing parts, before installing. The vendor will *not be responsible for costs* of installing or removing damaged doors.
4. Confirm the *opening* for the door matches the size on the *packing list*.

## Warnings and Cautions

We have provided many important safety messages in this manual about your Door. Always read and obey all safety messages.



This is the safety alert symbol.

This symbol alerts you to potential hazards that can kill, injure, or damage equipment.

All safety messages will follow the safety alert symbol and either the word “Warning” or “Caution.” These words mean:



**WARNING**

You can be killed or seriously injured if you don't follow instructions.



**CAUTION**

Equipment can be damaged or destroyed if you don't follow instructions.

All safety messages will tell you how to proceed to reduce the chance of death, injury, or damage to the Door.

## Important Safety Instructions – Read Prior to Installation

This installation must be performed by a qualified installer. To avoid injury from sharp metal edges, the installer must be equipped with protective clothing, gloves, and eyewear.

To reduce the risk of fire, electrical shock, injury, death, or damage when installing or repairing the Door, follow basic precautions, including the following:

 **WARNING:** Improper wiring or lack of proper ground can result in fire, electrical shock, injury or death. Disconnect power to the Door before performing any electrical repairs. Field wiring or electrical repair should be done by a licensed professional electrician. Follow all local building codes and laws for electrical installation.

 **WARNING:** Avoid installing the Door on windy days. The door panel or sections are difficult to handle in windy situations and could fall during installation.

 **WARNING:** When installing or servicing the Door, clear the area of children and unnecessary adults.

 **WARNING:** In case of electrical fire, disconnect the power supply. Do not use water on electrical fires. Smother the fire with an extinguisher rated for C-class fires.

 **WARNING:** Always keep your hands clear of moving parts when door is in motion. Use handles when operating the Door. Avoid loose fitting or hanging clothing.

 **CAUTION:** After changing any parts on the Door, always check the door gasket tightness and adjust as necessary.

 **CAUTION:** Per NEC 300-7, all raceways passing from different temperatures shall be sealed with putty or other method to stop the travel of moisture. Furthermore, all junction box cover plates shall be sealed. Verify these seals are in place and functioning properly after performing any service on the Door.

 **CAUTION:** If a Door becomes hard to operate, inoperative, or damaged, do not operate the Door until necessary adjustments or repairs have been made.

 **CAUTION:** Inspect the Door regularly for ice accumulation that might hinder its movement. De-ice before moving the Door.

 **CAUTION:** Inspect the Door regularly for proper operation and maintenance. Follow instructions listed in the Periodic Maintenance section.

## Attaching Door Frames to Wall

1. Verify that the door opening and wall are plumb, and the opening is square. Adjust as necessary.
2. Before installing the door frame, check for proper backing in the wall. See *Figure 1*.

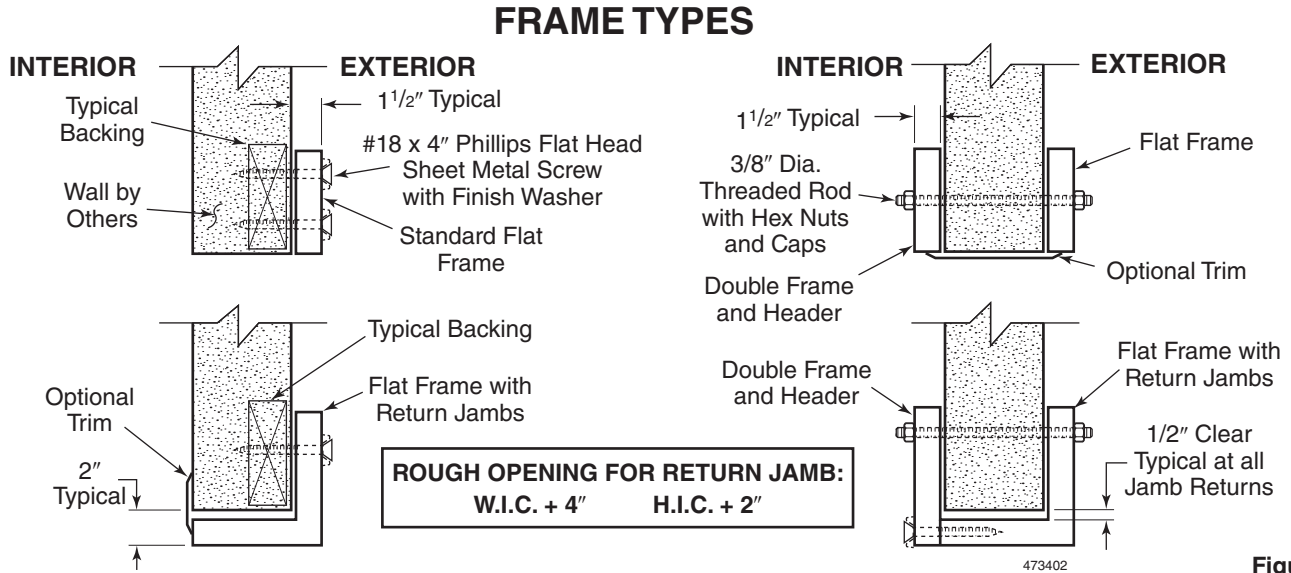

Figure 1

3. At job site, drill 5/16" holes in the frames and headers for mounting to the backing in the wall. Space holes 6" in from the end, then every 36". See *Figure 2*.
4. Stand the left and right frames up against the wall, one on each side of the door opening so they are located correctly. Check to see that the frames are plumb and square to the door opening.

**NOTE:** When installing a freezer door, a thermal break is required. Add *Silicone caulking* behind the side frames and Header Assembly before fastening to the wall.

Attach the frames to the wall with the #18 x 4" Phillips flat head sheet metal screws and finish washers that are provided. Verify that the frames are still plumb and square to the door opening. See *Figure 2*.

5. Mount the Sliding Door Track and Header assembly above the door frame. See *Figure 3*. For a single door, mount the end of the Track flush with the edge of the side frame. For a bi-parting door, the center stops on the Door Track should be centered above the door opening. In all cases, anchor the Door Header with the #18 x 4" Phillips flat head sheet metal screws and finish washers.
6. Seal with *Silicone caulking* around the side frames and header after tightening the screws.

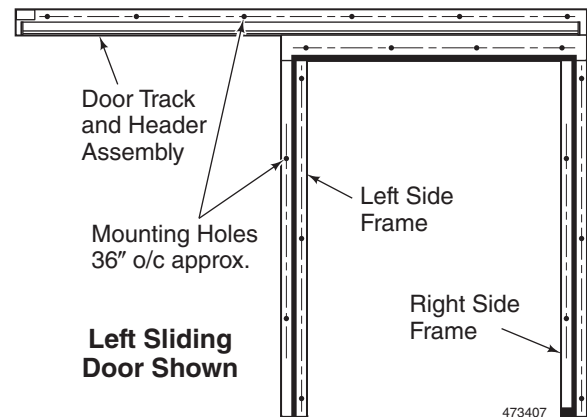

Figure 2

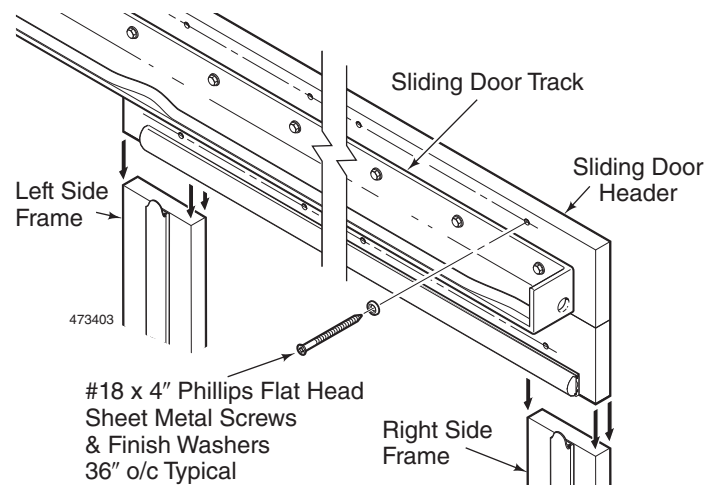

Figure 3

## Joining Door Sections with Cam Locks



**CAUTION:** All parts have been pre-assembled at the factory. No Drilling should be required. Be careful to not overdrive any fasteners.

Doors larger in width must be field assembled as follows:

1. Begin by laying the sections of the door face down on a clean and level surface. Block as needed so the door sections are aligned. See *Figure 4*.
2. Apply silicone caulk to both long edges, then slide the door sections together. Cam lock the sections with a 3/8" hex wrench (supplied). Turn clockwise until the lock is engaged with the Hinging pin. See *Figure 5*.
3. Note that interior and exterior surfaces of the door sections along the joint should be flush and smooth. Install cam hole covers. Add *Silicone caulking* to the seams between the panels on both interior and exterior sides.
4. Remove the Adjuster Rod and Jam Nuts. Install the 10 gauge Metal Plate at the top and the bottom of the door. Anchor the strips with #8 x 1-1/2" Phillips pan head screws that have been provided. Reinstall the Adjuster Rod. See *Figure 6*.

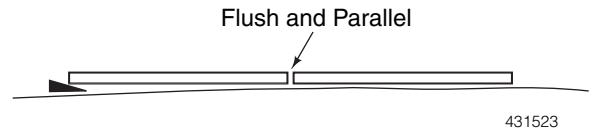

Figure 4

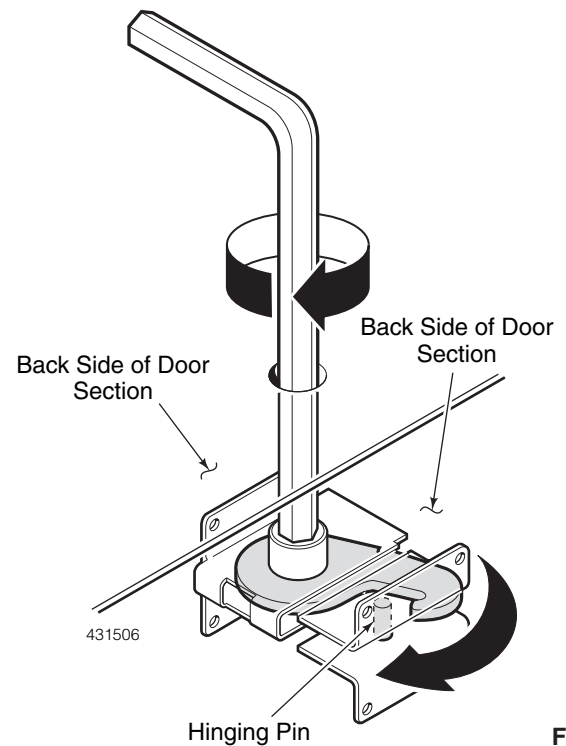

Figure 5

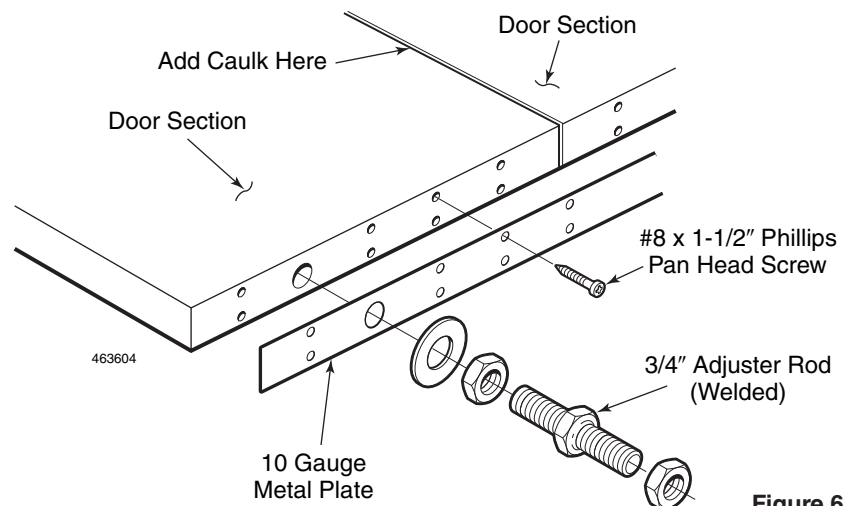

Figure 6

## Assemble and Install Door and Door Hanger

1. Install the Door Hanger on top of the door. Fasten it to the door with the Square Washers, flat washers, Jam Nuts, nylon Lock Nuts, and 3/4" Adjuster Rods. Make sure the Adjuster Rod comes through the nylon Lock Nut on the Square Washer no more than 1/16". Adjust the Door Hanger temporarily to 3-3/4" from the top of the door to the bottom of the Channel. Final adjustment is made after the Door is hanging on the Door Track. See Figure 7.
2. Place the door section next to the door opening and lean it against the steel Door Track. Be careful to not damage the Sweep Gasket at the bottom of the door section.
3. Lift the door and place the Track Rollers on the Round Welded Rod of the Door Track.
4. Install the Anti-Jump Bolt to keep the door on the track. Adjust to a gap of 1/16". See Figure 8.

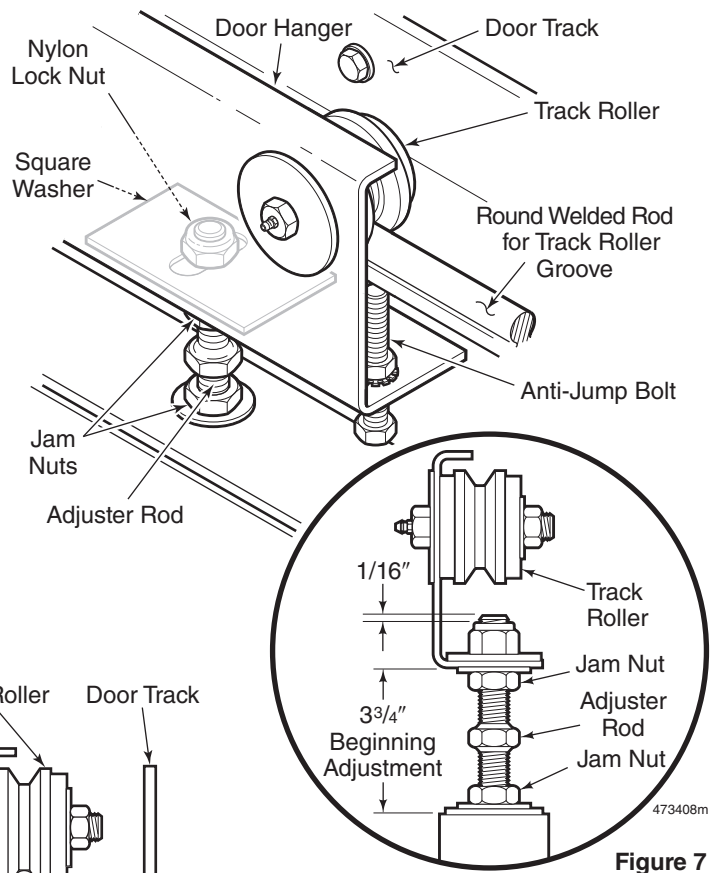

Figure 7

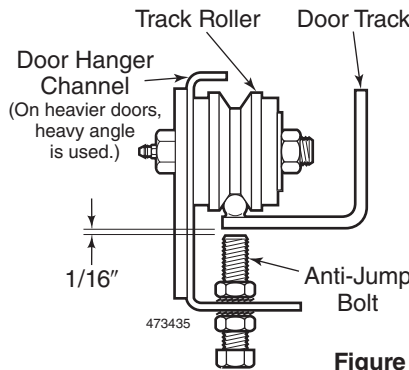

Figure 8

**WARNING:** Anti-Jump Bolts must be adjusted properly and Adjuster Rod Jam Nuts must be tightened against the Door Hanger Channel prior to operating the Door, even during the door leaf adjustment process, or damage may occur.

## Adjusting the Door Height

The Sweep Gasket should lift free of the floor when the Door is opened.

1. For a single slide door, set the door in the closed position and adjust the door height so the Sweep Gasket lightly touches the floor and the door lines up with the side frames. See Figure 9. To adjust the height, loosen the top and bottom Jam Nuts on both Adjuster Rods and raise or lower the door with the welded nut on the Adjuster Rod. Tighten the Jam Nuts to lock the door in position. See Figure 7.

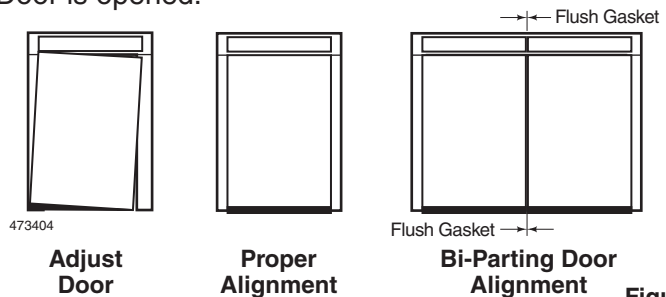

Figure 9

2. For a bi-parting door, set the doors in the closed position and adjust the door height so the Sweep Gasket lightly touches the floor. Use the Adjuster Rod to align the two door leaf sections for a proper seal where the doors come together. The door leaves should be parallel and have a uniform seal from top to bottom. See Figure 9. To adjust the height, loosen the top and bottom Jam Nuts on both Adjuster Rods and raise or lower the door leaf with the Adjuster Rod. Tighten the Jam Nuts to lock the door in position. See Figure 7.



## Stay Roller Installation

1. The purpose of the Stay Roller is to keep the bottom of the door against the gaskets in the closed position and to keep the door from kicking out at the bottom when moving.
2. If not found in the hardware box, the Stay Roller assemblies are secured to a piece of wood located on the front side of the Door Header. Remove them for installation. See Figure 10.
3. Be sure each Stay Roller Lock Nut is centered in the adjustment slot. Note the distance from the wall for *your* door size and type. See Figure 11. With Bi-Parting door(s) fully closed, position the center of the Trailing Edge Stay Roller  $3/4"$  in from the end of the Door Snubber Wedge. For Single Slide Doors, center the Leading Edge Stay Roller on the flat spot on the Door Snubber.
4. Use four  $3/8" \times 2-3/4"$  concrete wedge anchors to fasten each Stay Roller to the floor. See Figure 12.

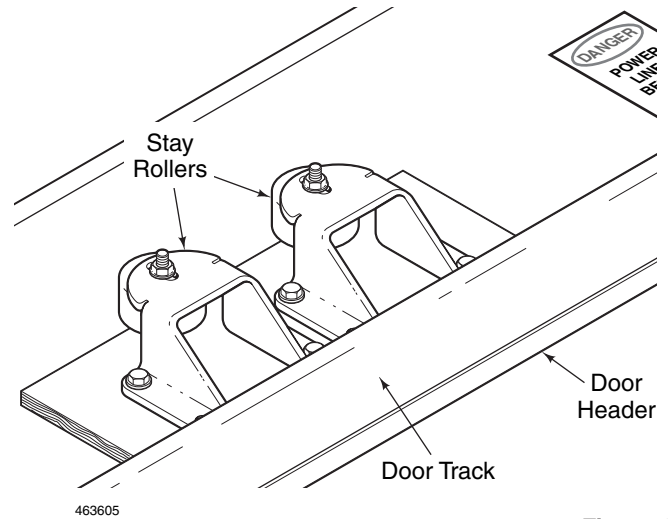

Figure 10

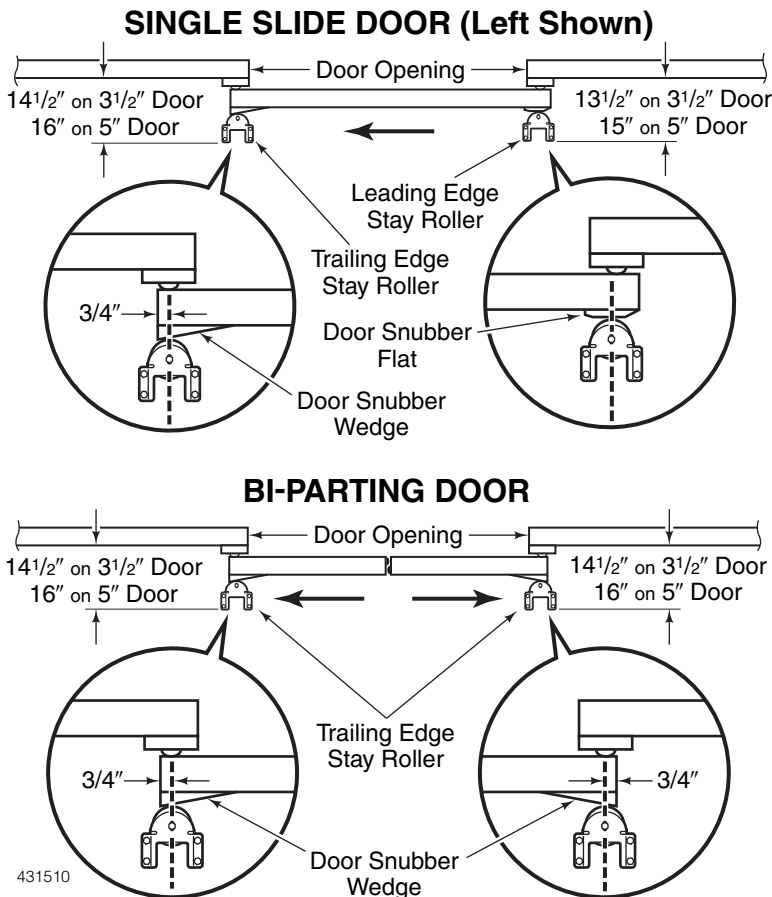

Figure 11

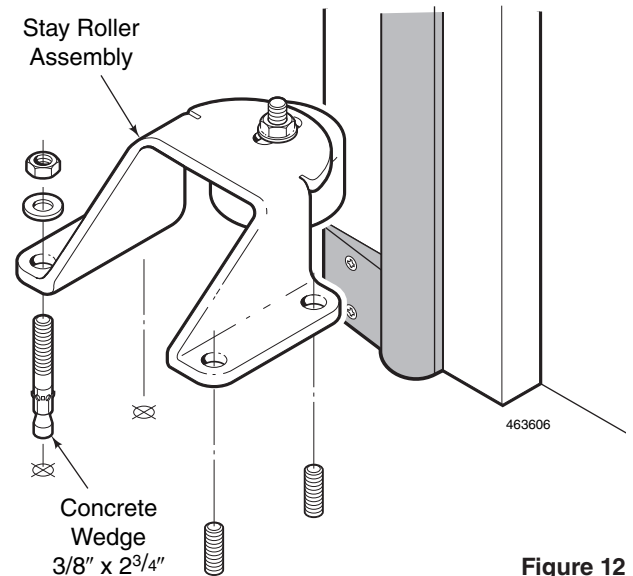

Figure 12

## Door Gasket Adjustment

1. With the door in the closed position, the gasket should be compressed 1/8". Check the gasket at the four corners of the door for proper compression. See Figure 13.

**CAUTION:** Do not adjust the door so tight that it becomes hard to open.

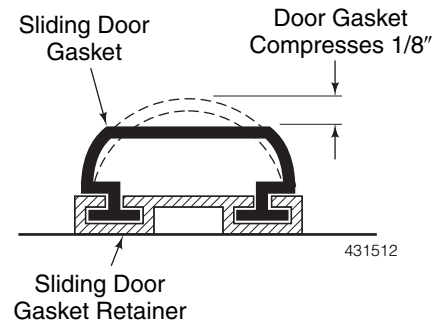

Figure 13

2. To adjust the gasket compression at the top of the door, loosen the top Jam Nut and push the door in until the gasket is properly compressed. Lock the door in place by tightening the top Jam Nut. See Figure 14.

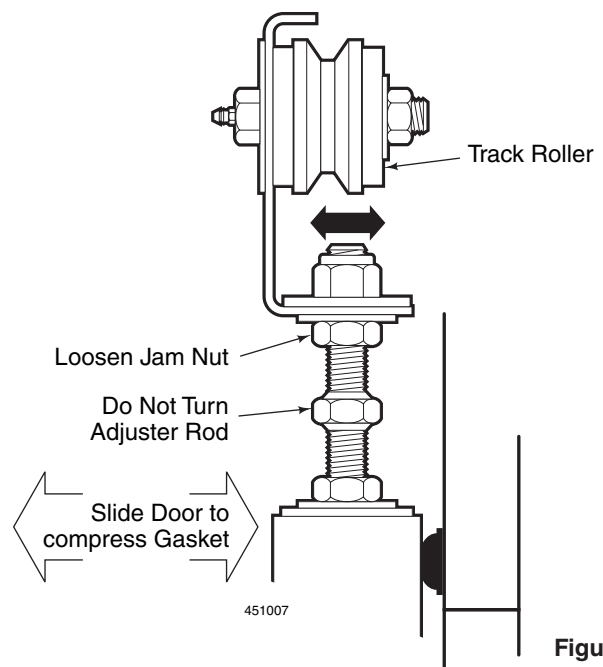

Figure 14

3. To adjust the gasket compression along the side frames, loosen the Lock Nut securing the UHMW Stay Roller to the Floor Bracket. Move the Stay Roller in the slotted hole until proper gasket compression is achieved. Tighten the Lock Nut to secure the Roller in position. On a Single Slide door, adjust the trailing edge first, then the leading edge. See Figure 15.
4. After the door has been hung and the gaskets have been adjusted for compression, go inside the room, close the door, and check all four sides for proper seal. Make sure no daylight is coming through. Check the center if you have a bi-parting door.

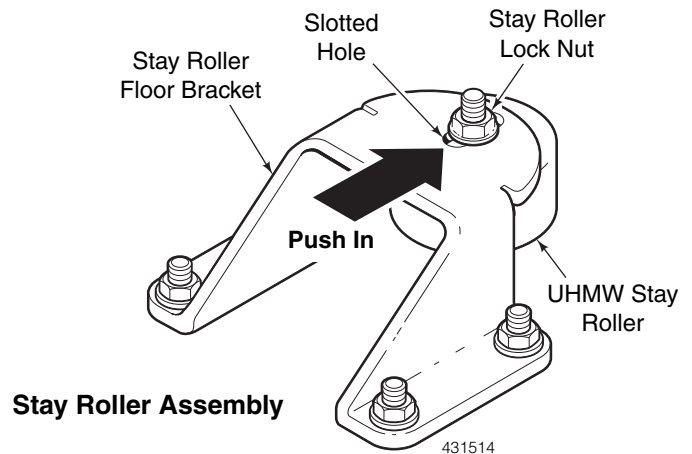

Figure 15



## Heat Cable Wiring

If the door is intended for freezer application, it will include 120VAC heaters in the form of thermostat controlled heat cable embedded in the door leaf. Heater lead wires terminate in a 2x4 Door Leaf J-Box located on the upper corner of the trailing edge of each door leaf.

Freezer doors are equipped with a Door Heater J-Box mounted on the Door Header. An SJO cable is connected to it. This cable must be shortened to the appropriate length and connected to the Door Leaf J-Box. Bi-Parting doors have a Door Heater J-Box and SJO cable mounted on each end of the Door Header. See Figure 16.

**NOTE:** The following connections should be made by a licensed professional electrician. In addition to these connections, the installer must provide a dedicated 120VAC circuit for the 2x4 Door Heater J-Box on the header. Current draw will vary with door model and size.

### Door SJO Cable(s)

1. Carefully determine the proper length for the SJO cable(s). It must have enough slack to move freely and not get stretched tight when the door is closed. In the open position, the cable loop from the Door Heater J-Box(es) on the Header to the Door Leaf J-Box(es) should extend approximately half way down the door. See Figure 17.
2. Cut the cable to length, slide it through the strain relief on the Door Leaf J-Box, and make the connections.
3. Verify after connection that the Door SJO cable(s) has enough slack to move freely.
4. Connect power from the 120VAC dedicated circuit to the Door Heater J-Box.

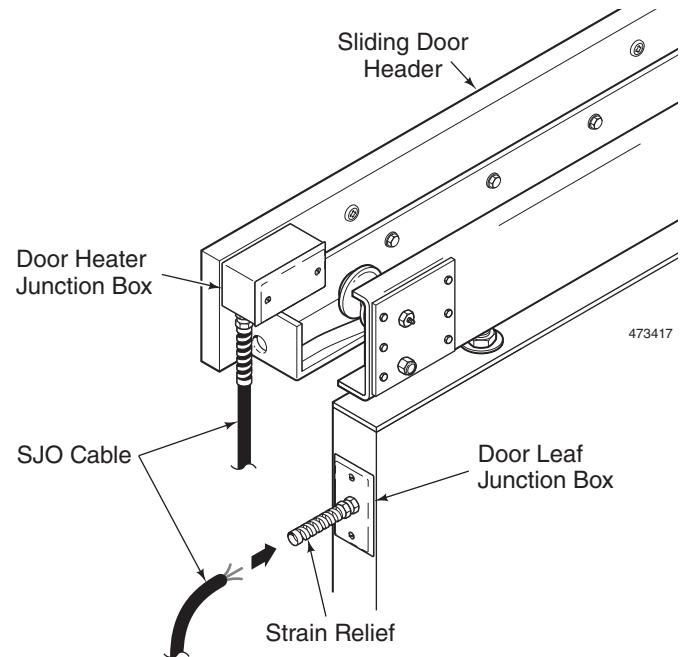

Figure 16

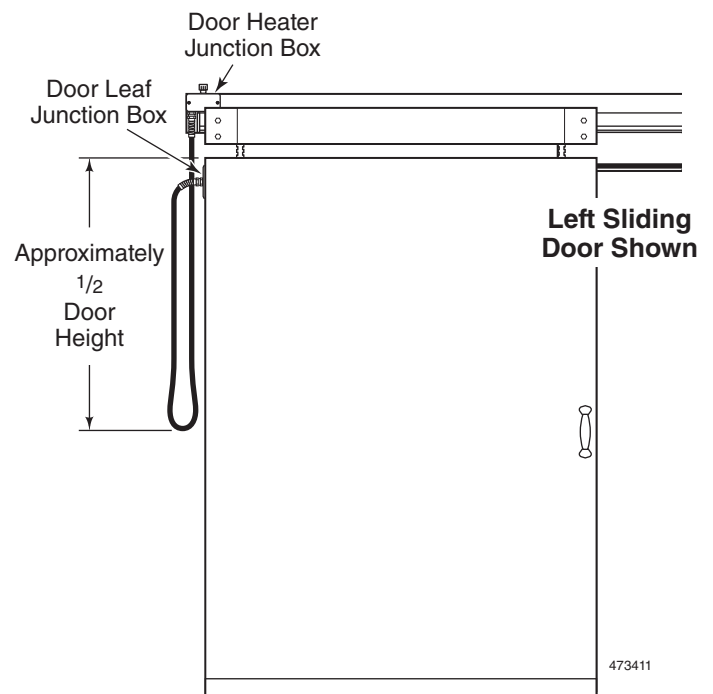

Figure 17

## PERIODIC MAINTENANCE

### Lubrication

Perform the following tasks on a regular basis. The frequency will be determined by the operating conditions at the installation site. In no case should the frequency be greater than 5000 cycles.

1. Track Rollers – Grease axles as needed with food grade machinery grease type NLGI #2 (Mobilgrease FM102 or the equivalent).
2. Stay Rollers – Lightly spray oil impregnated bushings with silicone lube monthly.

### Gaskets

1. Inspect the Bottom Neoprene Sweep Gasket for proper light-tight seal. Adjust or replace as needed.
2. Inspect the Sliding Door Gasket for proper 1/8" compression and light-tight seal. See *Figure 13*.

### Track Rollers

1. Check for undue wear and proper alignment, tighten or replace as needed.
2. Inspect track(s) for ice and debris. Clean track(s) thoroughly.

### Track Header, Gasket Header, and Side Frames

1. Check for loose Headers, Frames, and mounting screws. Tighten, replace or add mounting screws as needed.
2. Check for ice formation. Remove ice and adjust gaskets as needed. Verify door heaters are working properly.

# WARRANTY

**R-Plus Walk-In Cooler Cold Storage Doors** warrants to the original purchaser of its products that the foamed-in-place urethane panels purchased from R-Plus Walk-In Cooler Cold Storage Doors are free from defects in material and workmanship for a period of five (5) years and a one (1) year warranty on all other parts from the date of original shipment under normal use and service. This warranty is limited to replacement (FOB R-Plus Doors) of malfunctioning parts and does not include damage resulting from accident or malicious misuse.

## **Exclusive Warranty - No Implied Warranties**

This written and expressed warranty is the only warranty provided by R-Plus Walk-In Cooler Cold Storage Doors on the products they sell.

All warranties, which might otherwise be implied in this contract, are hereby excluded from this contract. This includes excluding the implied warrant of merchantability and fitness for a particular purpose. There are no warranties, which extend beyond the description of the warranties on the face hereof.

## **Exclusive Remedies**

The buyer's exclusive remedy under this warranty or for the breach of this warranty shall be the repair or the replacement of the defective part by R-Plus Walk-In Cooler Cold Storage Doors. R-Plus Walk-In Cooler Cold Storage Doors shall repair, or at its option replace, F.O.B. the factory, any part of the product which their examination shall disclose, to their satisfaction, to be defective.

No other remedy, including rejection of goods, revocation of acceptance, nor consequential damages for personal or property damage, nor incidental damages shall be allowed to the buyer of this product.

## **Hardware, Electrical Components and Accessories**

All hardware, electrical components and accessories are warranted to be free of defects in materials and workmanship under normal use and service for one (1) year from the date of original shipment.

## **Voidability of Warranty**

This warranty is void and of no force or effect, and the buyer shall have no expressed or implied warranties against defects, nor remedies for defects, if any of the following events occur:

- The door(s) are not installed within 120 days of original shipment
- The door(s) are not installed by a factory authorized installer
- The door(s) have been subjected to improper installation, misuse, abuse, neglect, alteration, accident, fire, flood, earthquake or other natural disasters.

This warranty does not include food or product loss, labor or transportation charges for replacement or repair of defective parts. This warranty is nontransferable. The original purchaser is the firm or individual to whom R-Plus Walk-In Cooler Cold Storage Doors originally sold this product.

\*R-Plus doors are designed to operate within the following temperature ranges:

Interior Freezer: -10 degrees F. to 32 degrees F.

Interior Cooler: 33 degrees F. to 100 degrees F.

Exterior Ambient Temperature: 65 deg F. to 80 deg F.

**WE MUST BE NOTIFIED UPON PLACEMENT OF THE ORDER IF OPERATING TEMPERATURES ARE OUTSIDE THE ABOVE NORMAL DESIGN TEMPERATURES TO PROPERLY DESIGN THE PRODUCT OR THE WARRANTY MAY BE VOIDED.**

# **R•PLUS**

**COLD STORAGE DOORS**

2271 NE 194th • Portland, Oregon 97230  
Toll Free (877) 320-3599 • Fax (503) 665-2929  
[www.RPlusDoors.com](http://www.RPlusDoors.com)

For the latest manuals and resources, just  
snap on the QR Code, or visit  
**[sp.rplusdoors.info](http://sp.rplusdoors.info)**

